



# 昆明康倍特输送带有限公司 KUNMING CONVEYOR BELT CO., LTD.

Address: Room 1602, Block B, Mo'er Building, No.60 Chuncheng Road, Kunming-650011, China  
 TEL: 0086 871 65136470, 65136474 FAX: 0086 871 65136492  
 Website: www.kmbelt.com.cn Email: kmbelt@163.com, sales@kmbelt.com.cn

## TYPE

### KCB-T50

## GENERAL CHARACTERISTICS:

POSITIVE DRIVING

HOMOGENEOUS BELT

ESPECIALLY FOR MEAT INDUSTRIES

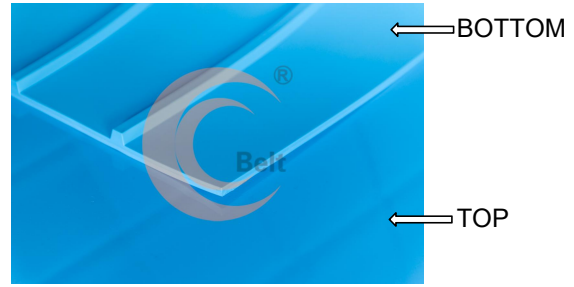

## TECHNICAL CHARACTERISTICS :

Total Thickness	7.5 mm
Thickness of base	3.0 mm
Height of teeth	4.5 mm
Stability of weft	Yes
Weight	4.3kg/m <sup>2</sup>
Working Temperatures	-20 °C to + 90 °C
<b>1. Top side</b>	
Material	Thermoplastic Polyurethane (TPU)
Color	Sky blue (SB)
Surface	Glossy
Hardness	95 ShA
<b>2. Tension Member</b>	
Material	Aramid fiber
Spacing between cords	20.0 mm
<b>3. Bottom side</b>	
Material	Thermoplastic Polyurethane (TPU)
Color	Sky blue (SB)
Surface	T50 Teeth
Hardness	95 ShA
Pitch between teeth	50 mm

## STRUCTURE DIAGRAM:

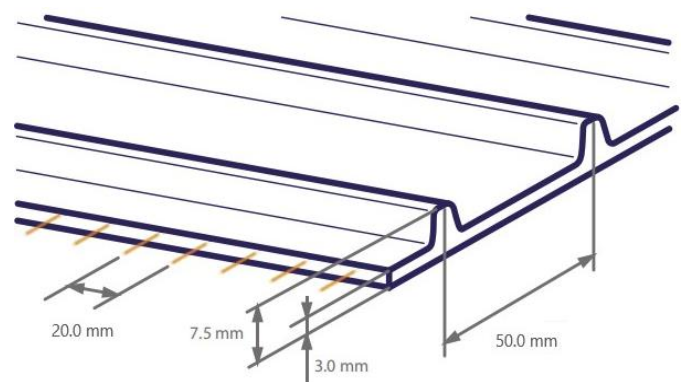

## MINIMUM PULLEY DIAMETERS:

Roller diameter in min. (23°C)	92 mm
--------------------------------	-------

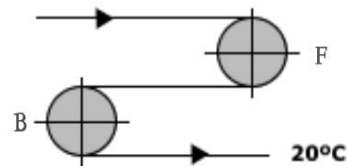

## BELT TENSION :

Max. Suggested Load	14 N/mm
Working load 1% elongation	16 N/mm

## FRICTION COEFFICIENTS ON:

Smooth Stainless Steel	0.6 (wet) / 0.4 (dry)
------------------------	-----------------------

## REMARKS

Max. manufacturing width	1200mm
--------------------------	--------

## CONVEYOR FRAME:

Horizontal Rollers	Yes
Slider bed	Yes
Troughed application	No

## SPECIAL CHARACTERISTICS:

Food grade	Yes, FDA
Oil resistant	Yes
Hydrolysis resistant	Yes
Bacteria resistant	Yes

Edited 11/02/23

We reserve the right to change any part of this specification without notification due to improvement or any other reasons